USER MANUAL

Thank you for purchasing our products, please take some minutes to read this manual before operating any of these laser projectors!



PR3000A-RGB

PR7000-RGB

PR9000-RGB

PR4000A-RGB

PR8000-RGB

PR10000-RGB

PR5000-RGB

PR5500-RGB

Notice

AVOID EYE OR SKIN EXPOSURE TO
DIRECT OR SCATTERED LIGHT
CLASS 4 LASER PRODUCT

Manufactured/ Certified by
Shenzhen Optlaser Technologies Co.,Ltd

www.optlaser.com

Content

INTRODUCTION	- - - - -	2
PACKING LIST	- - - - -	2
UNPACKING INSTRUCTIONS	- - - - -	2
GENERAL INFORMATION	- - - - -	2
<i>SAFETY NOTES</i>	- - - - -	3
LASER AND SAFETY NOTES	- - - - -	4
LABELLING REFERENCE	- - - - -	5, 6
PROPER USAGE	- - - - -	7
RIGGING	- - - - -	7
OPERATIONS	- - - - -	8, 9
INTERLOCK DIAGRAM	- - - - -	10
LCD Display Setting introduction	- - - - -	11
PR4 SERIES	- - - - -	12
INTRODUCTIONS of PR4 SERIES	- - - - -	13
Specifications of PR4SERIES	- - - - -	14
PR6 SERIES	- - - - -	15
INTRODUCTIONS of PR6 SERIES	- - - - -	16
Specifications of PR6 SERIES	- - - - -	17
PR8 SERIES	- - - - -	18
INTRODUCTIONS of PR8 SERIES	- - - - -	19
Specifications of PR8 SERIES	- - - - -	20
Display mode introduction	- - - - -	21
DMX CHART	- - - - -	22, 23
INTRODUCTIONS OF RE-ALIGNMENTS. REF.	- - - - -	24
Maintenance Instruction	- - - - -	25

INTRODUCTION

Thank you for purchasing our products. To optimize the performance of your laser, please read these operating instructions carefully and familiarize yourself with the basic operations of this system. These instructions contain important safety information regarding the use and maintenance of this system as well. Please keep this manual with the unit, for future reference. If you sell this product to another user, be sure that they also receive this document.

Notice

- We are constantly striving to improve the quality of our products. As such, the content of this manual may be changed without notice.
- We have tried our best to guarantee the accuracy of this manual. If you have any questions or find any errors, please contact us directly to help correct this.

PACKING LIST

Name	Qty(pcs)
LASER projector	1
AC power cord	1
Keys for Key switch	2
Power output connector	1
Remote Interlock connector	2
Allen key	1

UNPACKING INSTRUCTIONS

Open the package and carefully unpack everything inside.

Ensure all parts are present and in good condition.

Do not use any equipment that appears to be damaged.

If any parts are missing or damaged then please immediately notify your carrier or local distributor.

GENERAL INFORMATION

The following chapters explain important information about lasers in general, basic laser safety and some tips about

how to use this device correctly. Please read this information as it contains critical information you must be aware of, prior to using these system.

SAFETY NOTES

WARNING! These projectors are Class 4 laser products. It must never be used for audience-scanning applications. The output beam of the projector must always be at least 3 meters above the floor in the audience. See the Operating Instructions section for further information.

Please read the following notes carefully! They include important safety information about the installation, usage, and maintenance of this product.

- Keep this User Manual for future consultation. If you sell this product to another user, be sure that they also receive this document.
- Always make sure that the voltage of the outlet to which you are connecting this product is within the range stated on the decal or rear panel of the product.
- This product is not designed for use outdoors in adverse weather conditions. To prevent risk of fire or shock, do not expose this product to rain or moisture.
- Always disconnect this product from the power source before cleaning it or replacing the fuse.
- Make sure to replace the fuse with another of the same type and rating.
- If mounting it overhead, always secure this product to a fastening device using a safety chain or cable.
In the event of a serious operating problem, stop using the projector immediately. Never try to repair the unit except in a controlled environment under trained supervision. Repairs carried out by unskilled people can lead to damage or malfunction of the unit, as well as exposure to dangerous laser light.
- Never connect this product to a dimmer pack.
- Make sure the power cord is not crimped or damaged.
- Never disconnect the power cord by pulling or tugging on the cord.
- Never carry a product from the power cord or any moving part. Always use the hanging/mounting bracket or the handles.
- Always avoid eye or skin exposure to direct or scattered light from this product.
- Lasers can be hazardous and have unique safety considerations. Permanent eye injury and blindness is possible if lasers are used incorrectly. Pay close attention to each safety REMARK and WARNING statement in this user manual. Read all instructions carefully BEFORE operating this device.
- Never intentionally expose yourself or others to direct laser light.
- This laser product can potentially cause instant eye injury or blindness if laser light directly strikes the eyes.
- It is illegal and dangerous to shine this laser into audience areas, where the audience or other personnel could get direct laser beams or bright reflections into their eyes.
- It is a US Federal offense to shine any laser at aircraft.
- No service allowed by customer. There are no user serviceable parts inside the unit. Do not attempt any repairs yourself.
- Service is only to be handled by the factory or authorized factory trained technicians.
- Product is not to be modified by the customer.
- Caution – use of controls or adjustments or performance of procedures other than those specified herein may result in hazardous radiation exposure.

LASER AND SAFETY NOTES

STOP AND READ ALL THE LASER SAFETY NOTES BELOW

Laser Light is different from any other light sources with which you may be familiar. The light from this product can cause eye and skin injury if not set up and used properly. Laser light is thousands of times more concentrated than light from any other kind of light source. This concentration of light can cause instant eye injuries, primarily by burning the retina (the light sensitive portion at the back of the eye). Even if you cannot feel “heat” from a laser beam, it can still potentially injure or blind you or your audience. Even very small amounts of laser light are potentially hazardous even at long distances. Laser eye injuries can happen quicker than you can blink. It is incorrect to think that because these laser entertainment products use high speed scanned laser beams, that an individual laser beam is safe for eye exposure. It is also incorrect to assume that because the laser light is moving, it is safe. This is not true.

Since eye injuries can occur instantly, it is critical to prevent the possibility of any direct eye exposure. It is not legal to aim this laser projector into areas where people can be exposed. This is true even if it is aimed below people’s faces, such as on a dance floor.

- Do not operate the laser without first reading and understanding all safety and technical data in this manual.
- Always set up and install all laser effects so that all laser light is at least 3 meters (9.8 feet) above the floor on which people can stand. See the “Proper Usage” section later in this manual.
- After set up, and prior to public use, test the laser to ensure proper function. Do not use if any defect is detected.
- Laser Light - Avoid Eye or Skin Exposure to Direct or Scattered Light.
- Do not point lasers at people or animals.
- Never look into the laser aperture or laser beams.
- Do not point lasers in areas where people can potentially be exposed, such as uncontrolled balconies, etc.
- Do not point lasers at highly reflective surfaces, such as windows, mirrors and shiny metal objects. Even laser reflections can be hazardous.
- Never point a laser at aircraft, as this is a US Federal offense.
- Never point un-terminated laser beams into the sky.
- Do not expose the output optic (aperture) to cleaning chemicals.
- Do not use the laser if the housing is damaged, open, or if the optics appear damaged in any way.
- Never leave this device running unattended.
- In the United States, this laser product may not be purchased, sold, rented, leased or loaned for use unless the recipient possesses a valid Class 4 laser light show variance from the US FDA CDRH.
- This product must always be operated by a skilled and well-trained operator who is familiar with the data included in this manual. Note that use of this projector in the United States also requires a valid Class 4 laser light show variance from the CDRH as stated above.
- The legal requirements for using laser entertainment products vary from country to country. The user is responsible for the legal requirements at the location/country of use.
- Always use appropriate lighting safety cables when hanging this projector overhead.

LABELLING REFERENCE

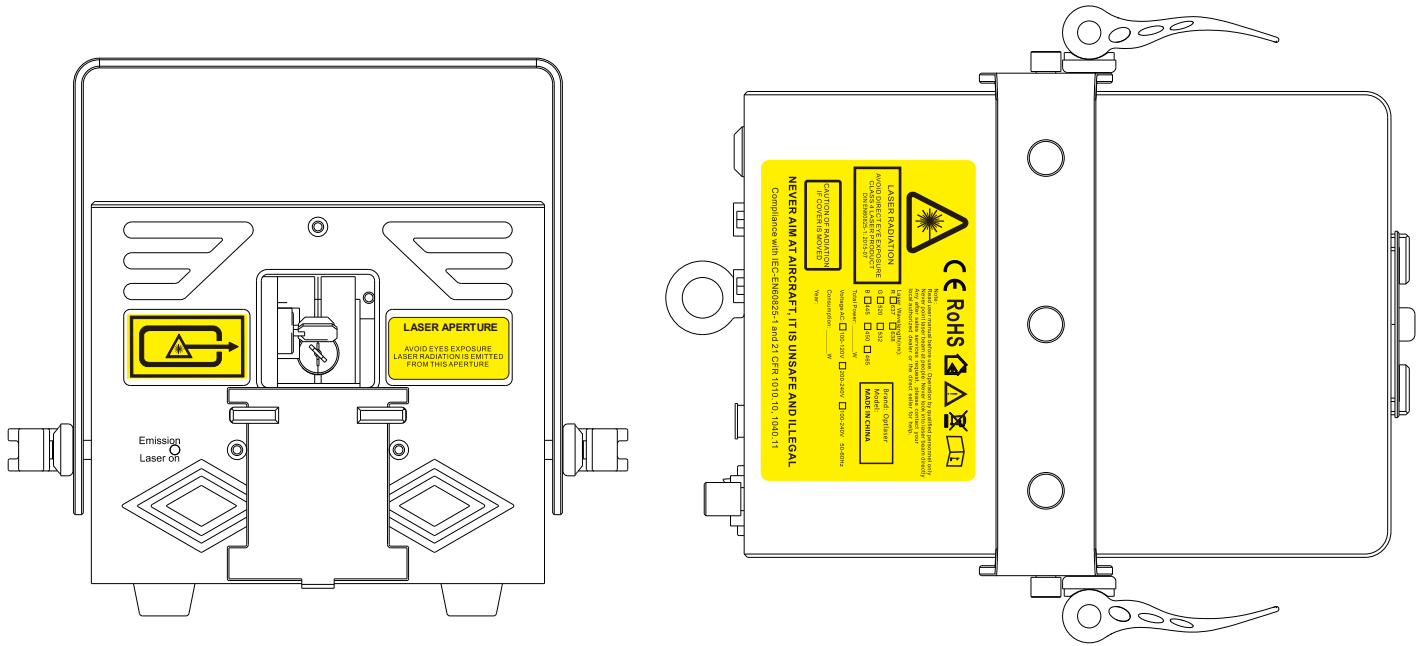

See the following reproductions of the product labels. All these labels must be intact and legible prior to be used on the projector.





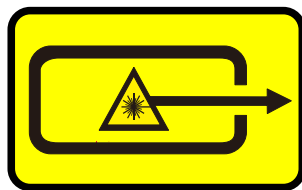

Hazard warning symbol

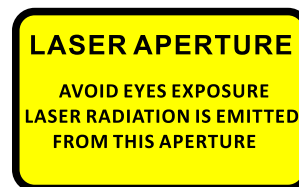

Aperture label



CE RoHS    

Note:
Read user manual before use | Operation by qualified personnel only
Never point laser beam at people | Never look into laser beam directly
Any after sales services request, please contact your local authorized dealer or the direct seller for help.

Laser Wavelength(nm):
R 637 638
G 520 532
B 445 450 465

Total Power: _____W
Voltage AC: 100-120V 200-240V 100-240V 50-60Hz
Consumption: _____W
Year:

LASER RADIATION
AVOID DIRECT EYE EXPOSURE
CLASS 4 LASER PRODUCT
DIN EN60825-1: 2015-07

Brand: Optlaser
Model:
MADE IN CHINA

CAUTION OF RADIATION
IF COVER IS MOVED

NEVER AIM AT AIRCRAFT, IT IS UNSAFE AND ILLEGAL
Compliance with IEC-EN60825-1 and 21 CFR 1010.10, 1040.11

PROPER USAGE

This product is for overhead mounting only. For safety purposes, this projector should be mounted on steady elevated platforms or sturdy overhead supports using suitable hanging clamps. In all cases, you must use safety cables.

International laser safety regulations require that laser products must be operated in the fashion illustrated below, with a minimum of 3 meters (9.8 ft.) of vertical separation between the floor and the lowest laser light vertically. Additionally, 2.5 meters of horizontal separation is required between laser light and audience or other public spaces.

The audience area can be passively protected by sliding the aperture cover plate upwards and fixing it in proper position by the two thumb screws.

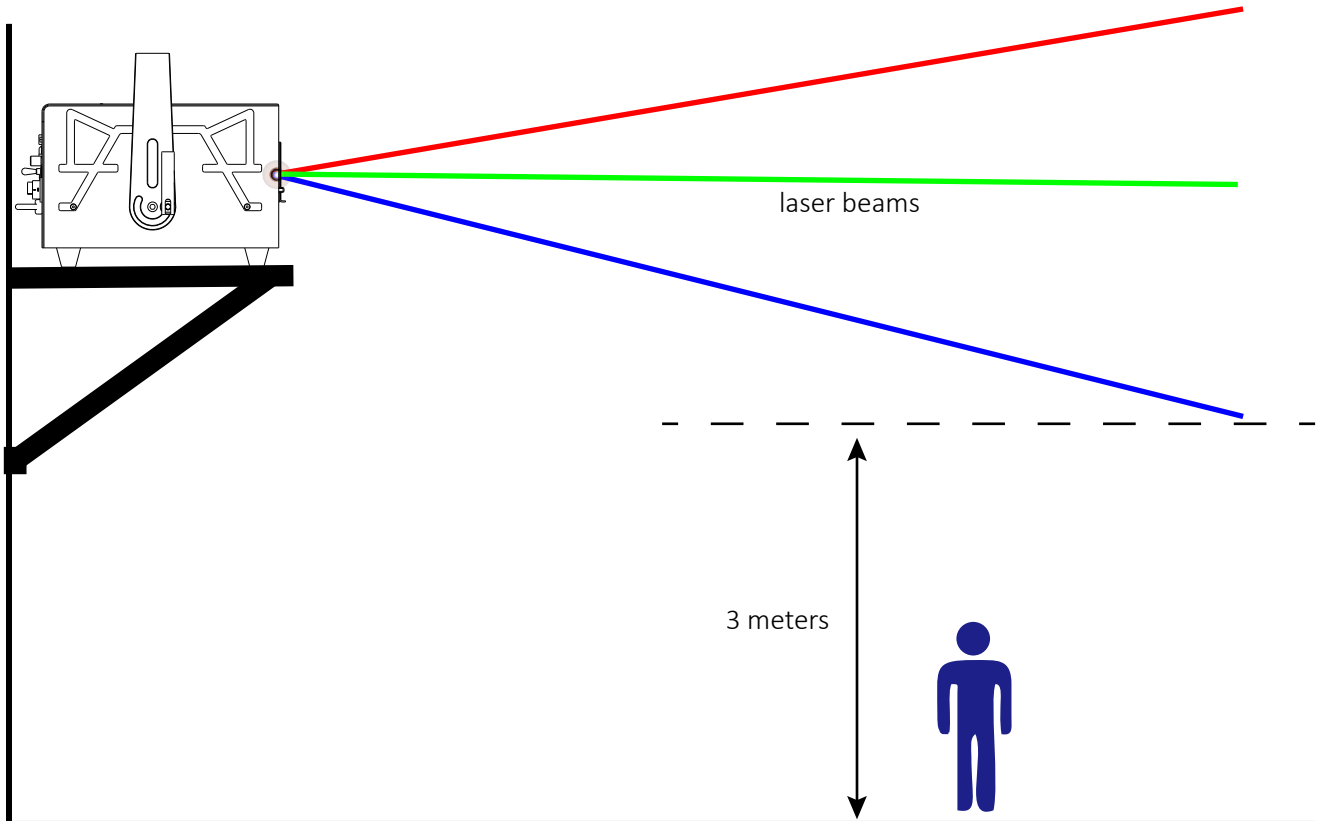

RIGGING

- Be sure that the structure onto which you are mounting this product can support its weight.
- Mount the product securely. You can do this with a screw, a nut, and a bolt. You may also use a mounting clamp if rigging this product onto a truss. The U-shaped support bracket has three mounting holes which may be used to secure the clamps to the projector.
- Always consider ease of access to the unit before deciding on a location for this product
- When mounting this product overhead, always use a safety cable.

Stainless steel cable(safety rope)



OPERATIONS

PD SERIES units come with diode-based only laser sources and all sources have beam correction ,thus have great beam show with analog FULL colors modulation.

The PD SERIES units can be controlled over ILDA and have a built-in memory with preset patterns ,also with SD-card slot for freely programs export onto it, that can be easily triggered through DMX. They can also be operated in automatic and sound-to-light mode.

The laser projector provides a master-slave-mode. Show lasers of the same series (slave projectors), connected via DMX to a main projector (master projector) project the same patterns like the master projector.

This Series will be applicable for clubs, bars, and those Small/medium venues or theater events, parties, business activities, large venues etc.

"PR series projectors are not supplied with standard "E-Stop Box" and "Remote Interlock bypass" Instead, a simplified "E-Stop Box" featured with "Mushroom switch" and "Key switch" will be supplied in the purchase accordingly to request.

The "E-stop Box" is generally with a CAT5 cable of 2m length unless there would be different requests.

If user doesn't need additional "E-Stop Switch", Then the "RJ45 jack interlock connector" should be inserted into the rear plate of the projector's INTERLOCK position(with silkscreen INTERLOCK marking) ,only by this way user will be able to light up the laser projector during operations.

Several steps to start up the laser projector(s)

1. Use the included power cord to connect the laser device to a proper power outlet(AC100-240V, 50/60Hz)
2. Use one of the included keys(2 sets included in the package, either one of them will work) to insert into the key-chassis and switch to the "ON" position
3. Use one of the the included INTERLOCK connectors to insert into the INTERLOCK position on the backplate of the device. (2 x RJ45 connectors(well made) included in the package)

Remark: There are 2 positions for INTERLOCK on the backplate of the devices $\geq 10W$ herein, either one of the positions will work(one only position needs to be with INTERLOCK connector inserted if the laser projector will be used alone. Both INTERLOCK positions will work if user wants to daisy chain 2 or more laser projectors through **E-stop box**.

4. Turn on the power switch from  to , then the laser device will start output laser light.

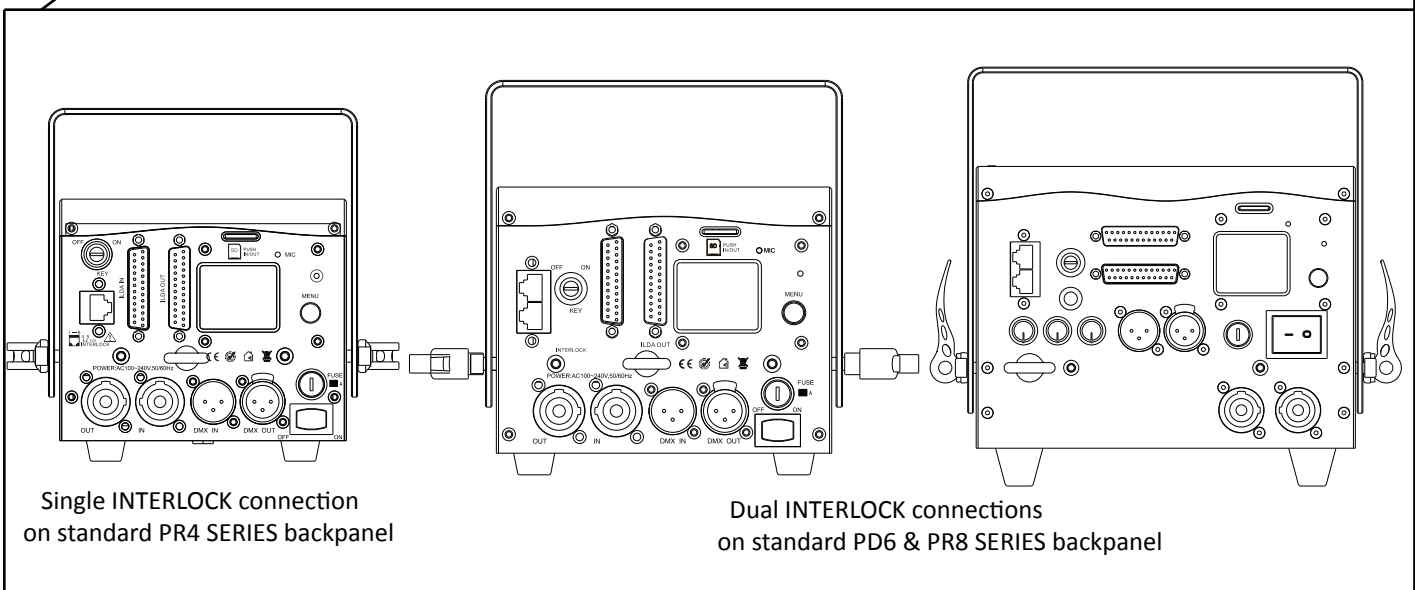

INTERLOCK CONNECTION DIAGRAM

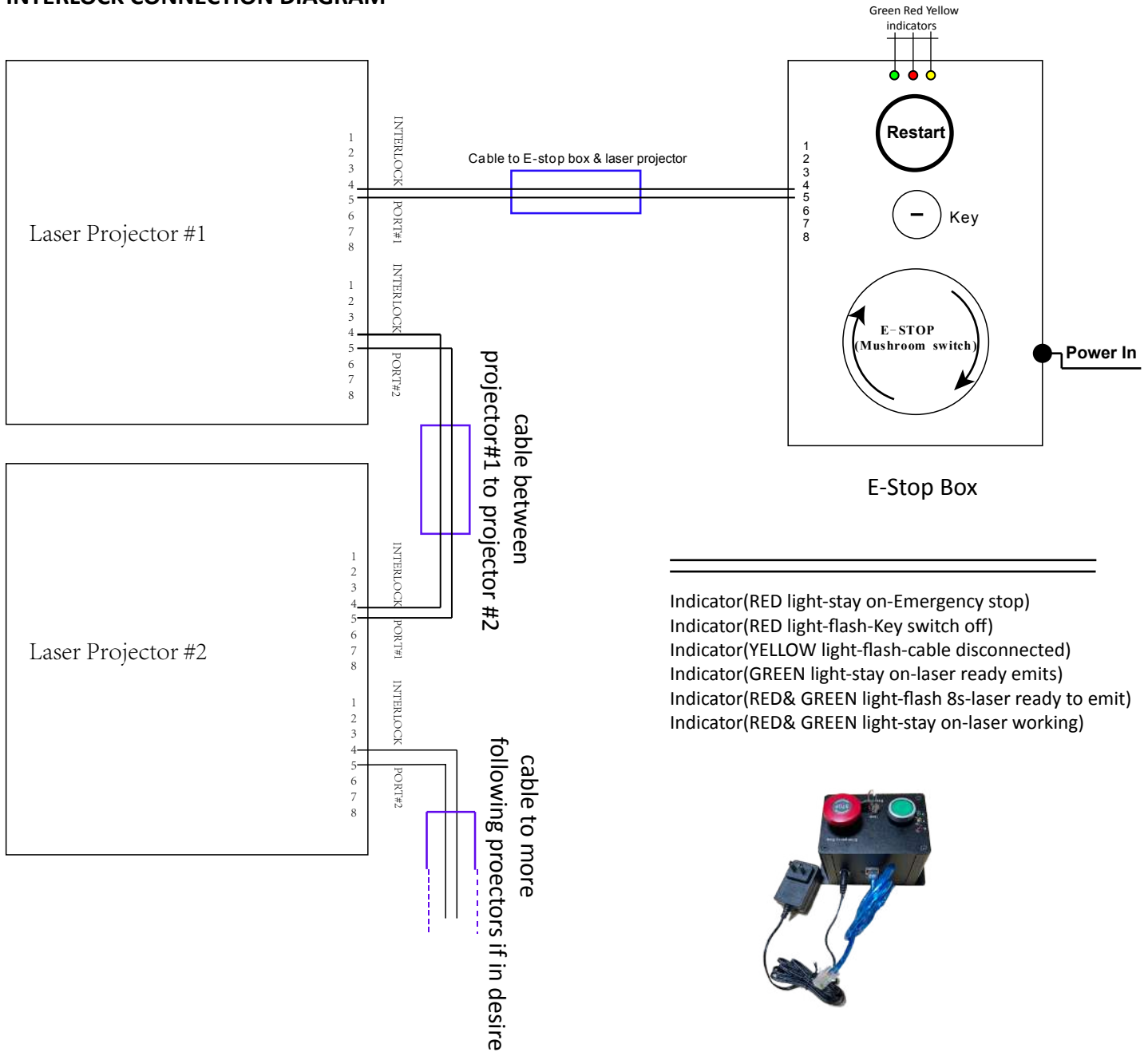

There may be a few models of the show systems that do not have the DUAL INTERLOCKS due to the limited space inside the compact size of the system to have the board assembled, therefore, remote interlock control in a low(daisy-chain) for them is not possible.

According to safety regulations in the US, CLASS 4 laser show systems must be equipped with the safety elements such as mechanical shutter plate to prevent a potential single laser beam shot. We're capable of carrying out laser systems with such requirements, upon order request.

Mechanical shutter plate

Laser beams at Galvoscaner's mirrors

LCD Display Setting introduction

Note:

All the contents listed on the LCD display can be freely changed to the preferable status. The most important step is to “double-click” the menu knob to SAVE the preferred status when all selections/settings get done. (The other settings should be operated step by step as DMX setting reference as the guidance following)

e.g. Default Status

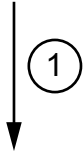

DMX Address	001
Show Mode	Auto
Program	Progr 1
SD file	No SD
Size X	-100 to 100
Size Y	-100 to 100
Speed	30
DMX STATE	Show Mode
Slave Mode	Slave
X Phasic	Positive
Y Phasic	Positive
Color Mode	RGB
Laser Lock	Off
Sound sense	080
SD Sound	Off
Highlight	000
ILDA Lock	Off
Load Flash	Off
Update Prog	Off
R	100
G	100
B	100
Recording DMX	Off
Language	English

Click the DMX column once and manually rotate the menu knob to change the DMX address(1-17 for options)



DMX Address	030
Show Mode	Auto
Program	Progr 1
SD file	No SD
Size X	-100 to 100
Size Y	-100 to 100
Speed	30
DMX STATE	Show Mode
Slave Mode	Slave
X Phasic	Positive
Y Phasic	Positive
Color Mode	RGB
Laser Lock	Off
Sound sense	080
SD Sound	Off
Highlight	000
ILDA Lock	Off
Load Flash	Off
Update Prog	Off
R	100
G	100
B	100
Recording DMX	Off
Language	English

Double-click the menu knob to save the preferred status.(When this step done, the background of the status will turn to red)



DMX Address	030
Show Mode	Auto
Program	Progr 1
SD file	No SD
Size X	-100 to 100
Size Y	-100 to 100
Speed	30
DMX STATE	Show Mode
Slave Mode	Slave
X Phasic	Positive
Y Phasic	Positive
Color Mode	RGB
Laser Lock	Off
Sound sense	080
SD Sound	Off
Highlight	000
ILDA Lock	Off
Load Flash	Off
Update Prog	Off
R	100
G	100
B	100
Recording DMX	Off
Language	English

Actual view of the LCD display gets lightened on, you need to rotate the menu knob to choose the needed status then make the preferable settings.



Important Remark:

While there's no ILDA signal input and if you don't need the devices to run in AUTO mode, you can make the setting on “DMX STATE” from “Show” switching to “Black”, then will bypass the “AUTO mode”.

PR4 SERIES

Standard Versions(without FB4 built-in)

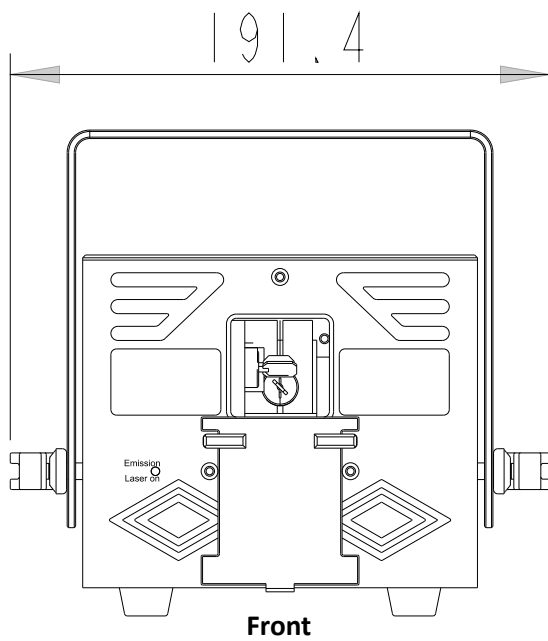
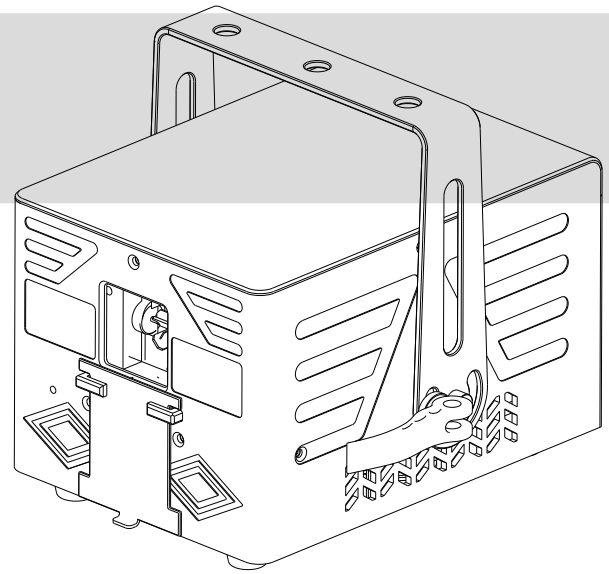

Front

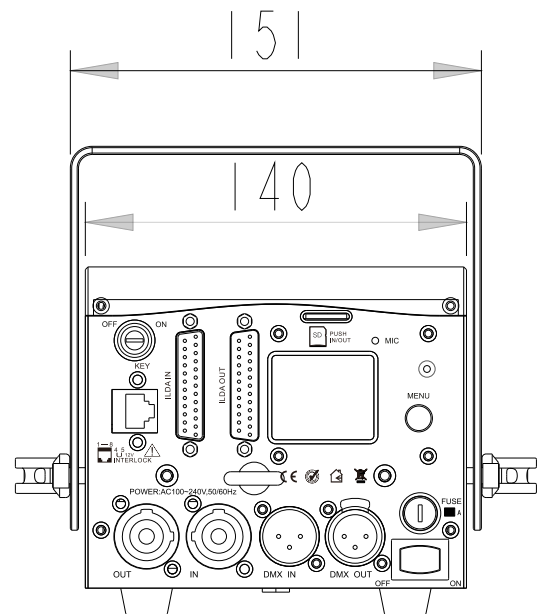

Rear

Size(mm)

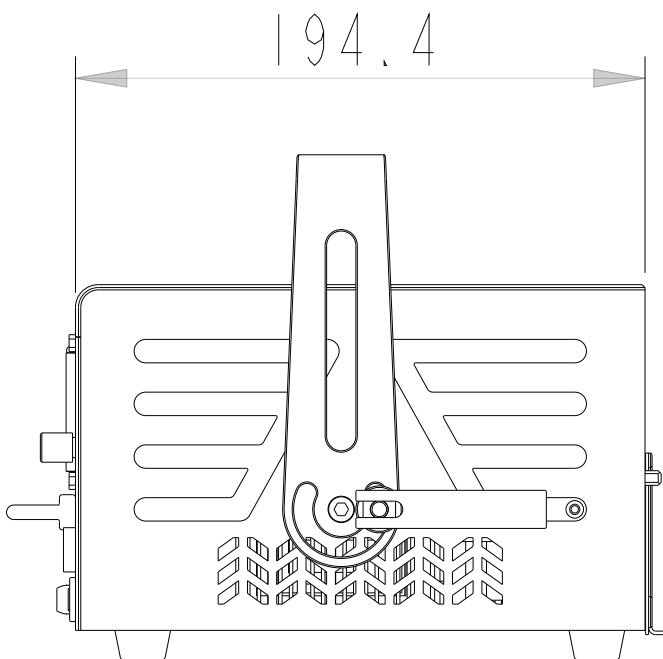

Side

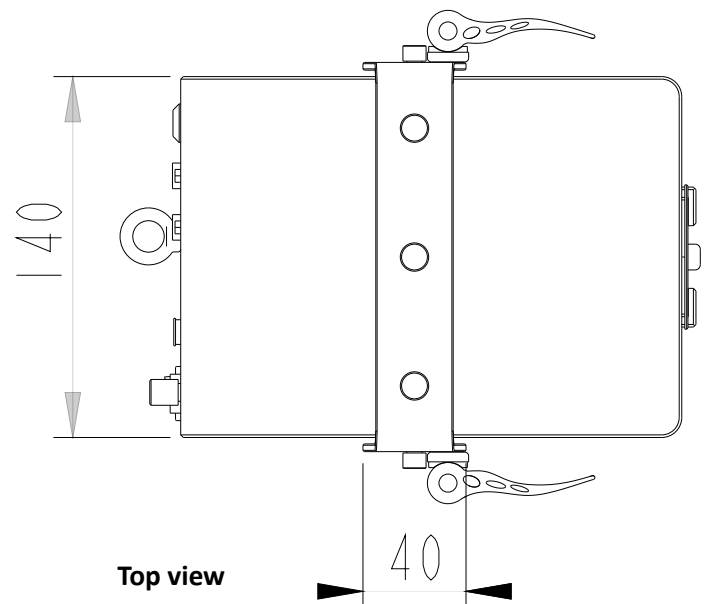

Top view

INTRODUCTIONS of PR4 SERIES

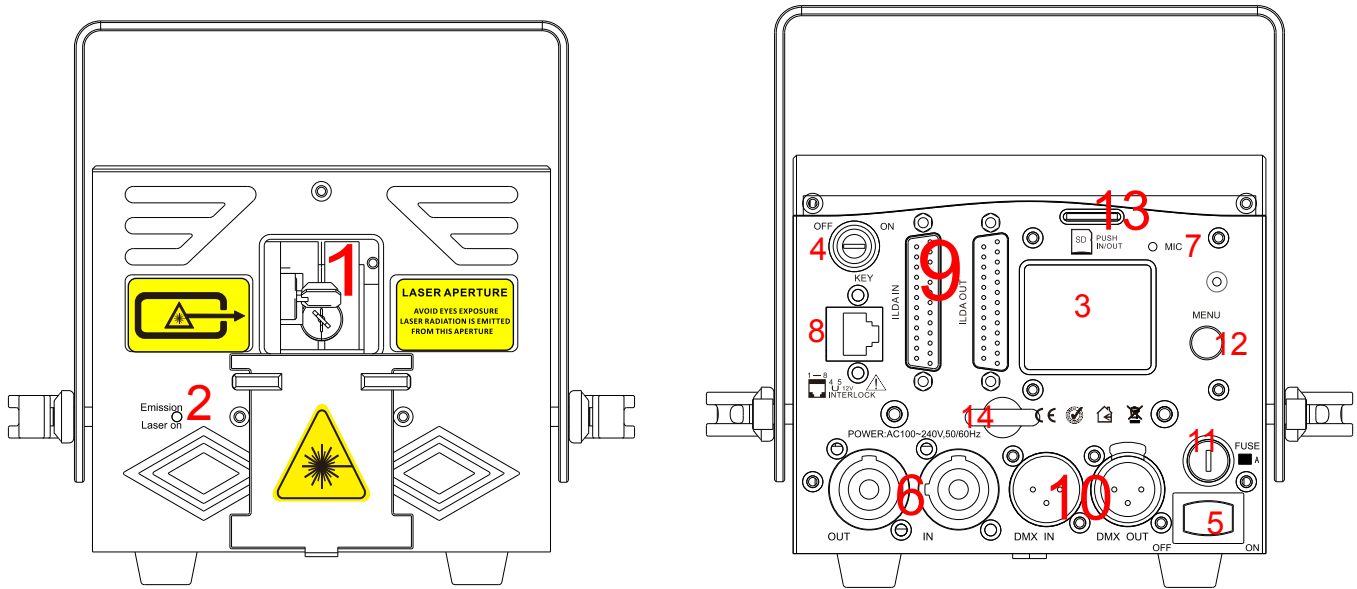

1	Laser aperture	(covered by masking plate) DO NOT look directly into this aperture once the masking plate gets loosen
2	Laser Emission	When this indicator is lit up the laser system is ready to emit the laser radiation as soon as it receives instructions from control software.
3	LCD Display	Integrated with multi settings on the projector, please refer to detailed settings (on Page 11.) for the LCD
4	Keyhole	Key Switch, laser output is available when the key is moved to position “on”
5	Power Switch	Power On/Off
6	PowerCON Input & Output	Power connections input and output
7	MicroPhone	Sound receiver
8	INTERLOCK (RJ45 jack)	Laser output is available only when the interlock is connected. It could be used to connect a laser emergency switch(E-stop box).
9	ILDA Input & Output	DB25 connections input and output for ILDA mode display
10	DMX Input & Output	3-pin DMX connections input and thru for DMX512 mode display
11	FUSE	Safety element; current rating 4amps
12	Menu knob for LCD Setting	The knob for the main settings on LCD, click it to wake the LCD and rotate it for corresponding status setting
13	SD-Card Slot	Slot for SD-Card which you may have your own laser files to export on
14	Safety Ring	The ring for enwinding a safety rope when the laser device will be installed on out-of-reach locations.

★ Specifications of PR4 SERIES

Type of Laser	Pure diode-based full colors(semiconductor diode laser systems)																				
Laser Classification	Class 4																				
Laser Power(mW)	<table border="1"> <thead> <tr> <th>Model</th> <th>λ 638nm</th> <th>520nm</th> <th>445nm</th> </tr> </thead> <tbody> <tr> <td>PR3000A-RGB</td> <td>R/650mW+</td> <td>G/800mW+</td> <td>B/1500mW</td> </tr> <tr> <td>PR4000A-RGB</td> <td>R/1300mW+</td> <td>G/1000mW+</td> <td>B/2000mW</td> </tr> <tr> <td>PR5000-RGB</td> <td>R/1300mW+</td> <td>G/1200mW+</td> <td>B/2500mW(465nm)</td> </tr> <tr> <td>PR5500-RGB</td> <td>R/1300mW+</td> <td>G/1200mW+</td> <td>B/3000mW</td> </tr> </tbody> </table> <p>Except for the listed models, the PR4 also covers several other mono color projectors, such as 3W red, 5W green and 9W blue.</p>	Model	λ 638nm	520nm	445nm	PR3000A-RGB	R/650mW+	G/800mW+	B/1500mW	PR4000A-RGB	R/1300mW+	G/1000mW+	B/2000mW	PR5000-RGB	R/1300mW+	G/1200mW+	B/2500mW(465nm)	PR5500-RGB	R/1300mW+	G/1200mW+	B/3000mW
Model	λ 638nm	520nm	445nm																		
PR3000A-RGB	R/650mW+	G/800mW+	B/1500mW																		
PR4000A-RGB	R/1300mW+	G/1000mW+	B/2000mW																		
PR5000-RGB	R/1300mW+	G/1200mW+	B/2500mW(465nm)																		
PR5500-RGB	R/1300mW+	G/1200mW+	B/3000mW																		
Scanning-system	40 kpps ILDA@8° , Scan angle Max 60°																				
Beam Size@aperture	2.5*6 mm																				
Beam Divergence	<1.2 mRad																				
Modulation	>60 KHz																				
Power Supply	AC 100-240V, 50/60Hz																				
Power Consumption	93W to 95W, varied by laser power ranges.																				
Net Weight	3.42 kg																				
Dimension	156*224*125mm																				
Controls	Auto, Sound to light, SD-Card, DMX512 , ILDA																				
Operation Temperature	minus 20 °C to 40 °C																				
Protection Rating	IP54																				
Safety elements	Keyed interlock, emission delay, magnetic interlock, scan-fail safety, mechanical shutter(on request), adjustable aperture masking plate.																				
Important statement	Due to Advanced Optical Correction technology used in our laser systems the optical power output of each laser colour within the system may slightly differ from the specification of respective laser module(s) installed. This does not affect the total guaranteed power output.																				

PR6 SERIES

Standard Versions(without FB4 built-in)

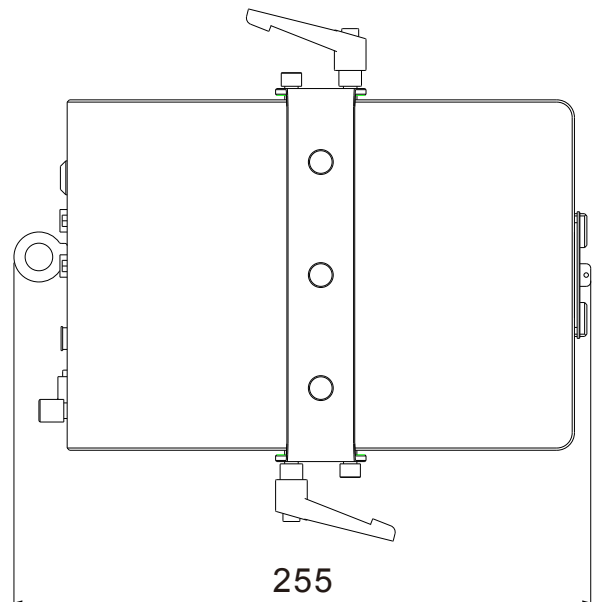
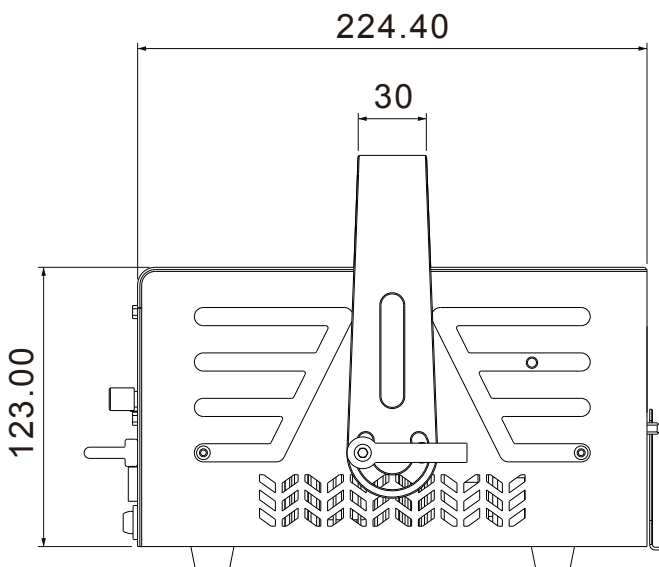
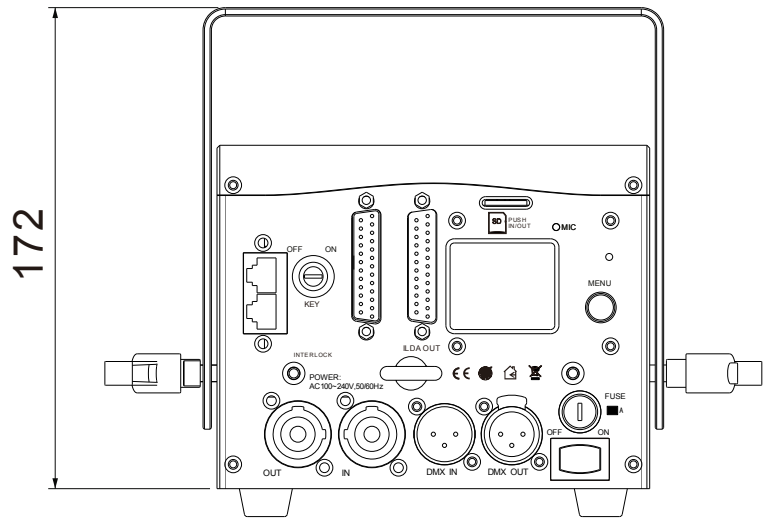
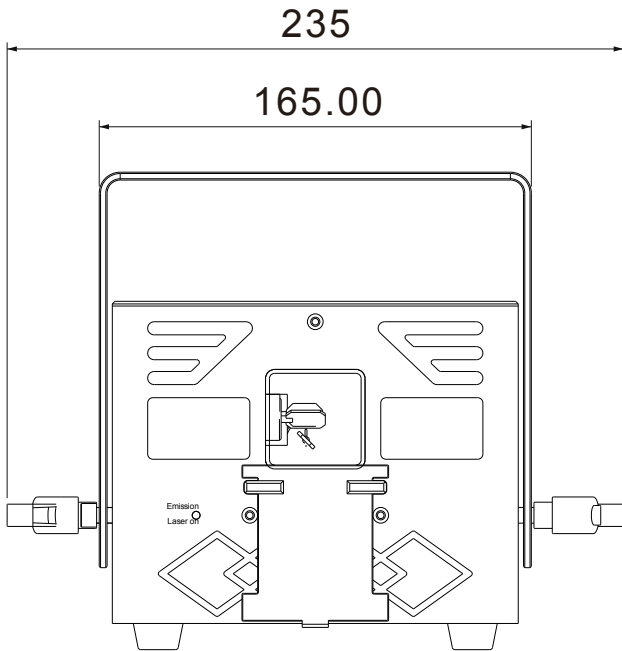
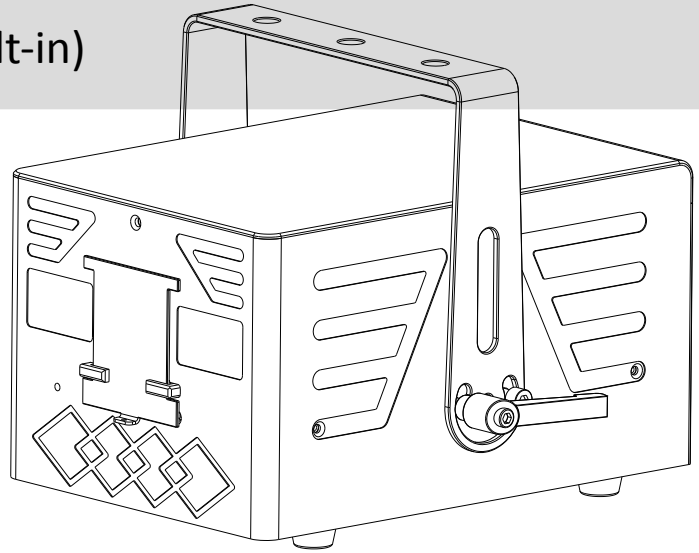

INTRODUCTIONS of PR6 SERIES

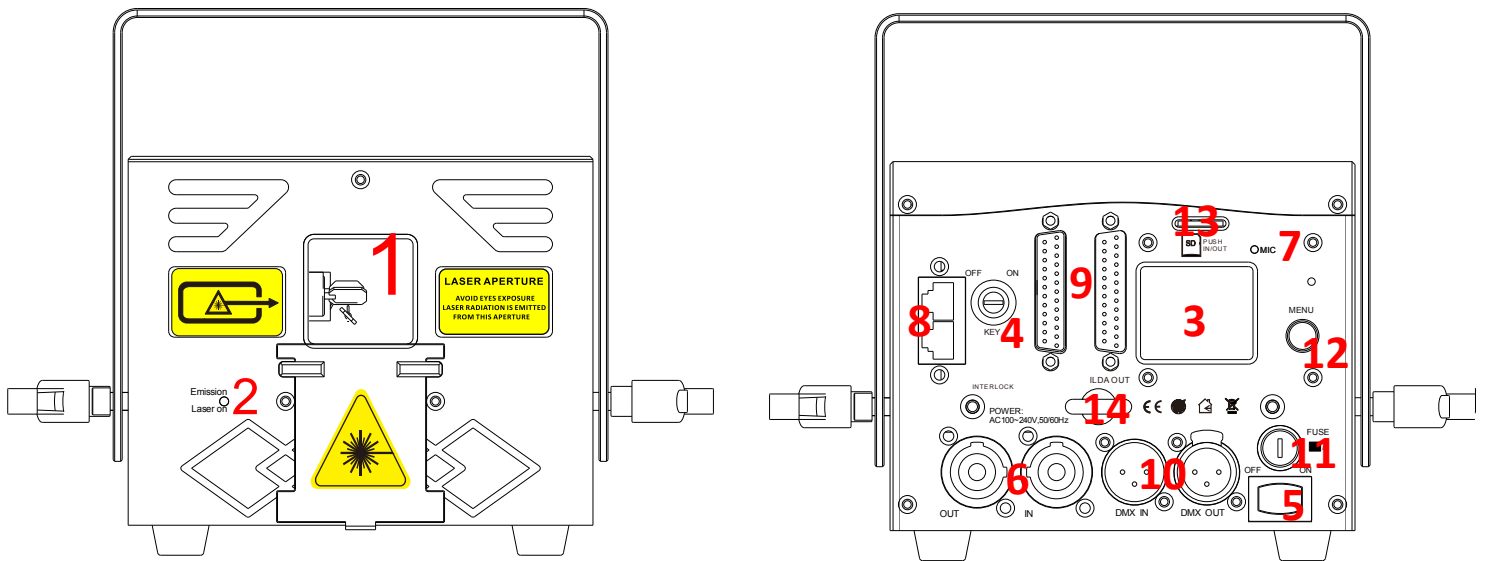

1	Laser aperture	(covered by masking plate) DO NOT look directly into this aperture once the masking plate gets loosen
2	Laser Emission	When this indicator is lit up the laser system is ready to emit the laser radiation as soon as it receives instructions from control software.
3	LCD Display	Integrated with multi settings on the projector, please refer to detailed settings (on Page 11.) for the LCD
4	Keyhole	Key Switch, laser output is available when the key is moved to position “on”
5	Power Switch	Power On/Off
6	PowerCON Input & Output	Power connections input and output
7	MicroPhone	Sound receiver
8	INTERLOCK (RJ45 jack)	Laser output is available only when the interlock is connected. It could be used to connect a laser emergency switch(E-stop box).
9	ILDA Input & Output	DB25 connections input and output for ILDA mode display
10	DMX Input & Output	3-pin DMX connections input and thru for DMX512 mode display
11	FUSE	Safety element; current rating 4amps
12	Menu knob for LCD Setting	The knob for the main settings on LCD, click it to wake the LCD and rotate it for corresponding status setting
13	SD-Card Slot	Slot for SD-Card which you may have your own laser files to export on
14	Safety Ring	The ring for enwinding a safety rope when the laser device will be installed on out-of-reach locations.

★ Specifications of PR6 SERIES

Type of Laser	Pure diode-based full colors(semiconductor diode laser systems)												
Laser Classification	Class 4												
Laser Power	<table border="1"> <thead> <tr> <th>Model</th> <th>638nm</th> <th>520nm</th> <th>445nm</th> </tr> </thead> <tbody> <tr> <td>PR7000-RGB</td> <td colspan="3">R/2000mW+G/2000mW+B/3000mW</td> </tr> <tr> <td>PR8000-RGB</td> <td colspan="3">R/2000mW+G/3000mW+B/3000mW</td> </tr> </tbody> </table>	Model	638nm	520nm	445nm	PR7000-RGB	R/2000mW+G/2000mW+B/3000mW			PR8000-RGB	R/2000mW+G/3000mW+B/3000mW		
Model	638nm	520nm	445nm										
PR7000-RGB	R/2000mW+G/2000mW+B/3000mW												
PR8000-RGB	R/2000mW+G/3000mW+B/3000mW												
Scanning-system	40kpps ILDA@8° , Scan angle Max 60°												
Beam Size@aperture	3.5*6.5 mm												
Beam Divergence	<1.1 mRad												
Modulation	>60 KHz												
Power Supply	AC 100-240V, 50/60Hz												
Power Consumption	120W												
Net Weight	3.88 kg												
Dimension	224*165*123(H)mm, Height 172mm when bracket included.												
Controls	Auto, Sound to light, SD-Card, DMX512 , ILDA												
Operation Temperature	minus 20℃ to 40℃												
Protection Rating	IP54												
Safety elements	Interlock, emission delay, magnetic interlock, scan-fail safety, mechanical shutter, adjustable aperture masking plate.												
Important statement	Due to Advanced Optical Correction technology used in our laser systems the optical power output of each laser colour within the system may slightly differ from the specification of respective laser module(s) installed. This does not affect the total guaranteed power output.												

PR8 SERIES

Standard Versions(without FB4 built-in)

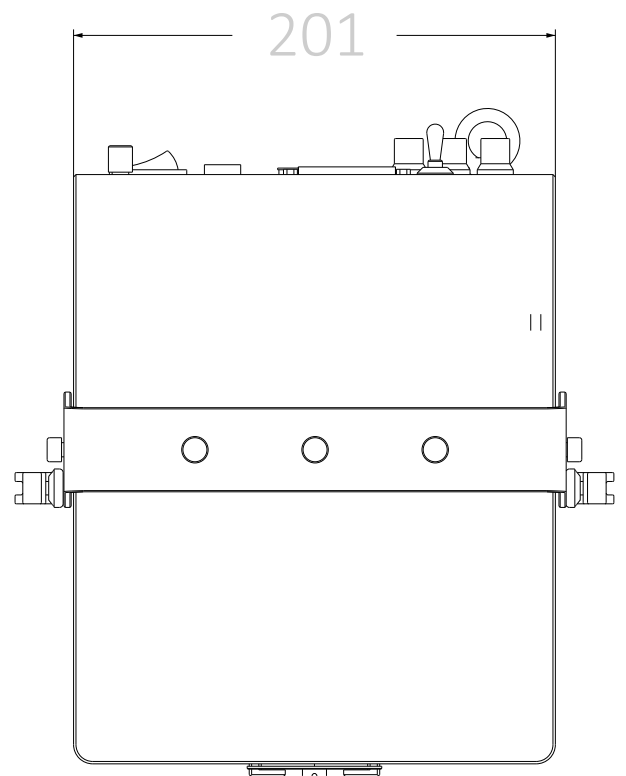
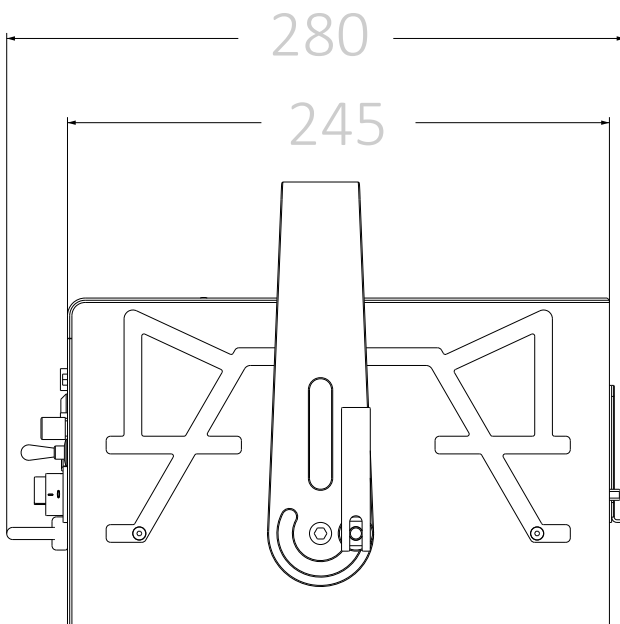
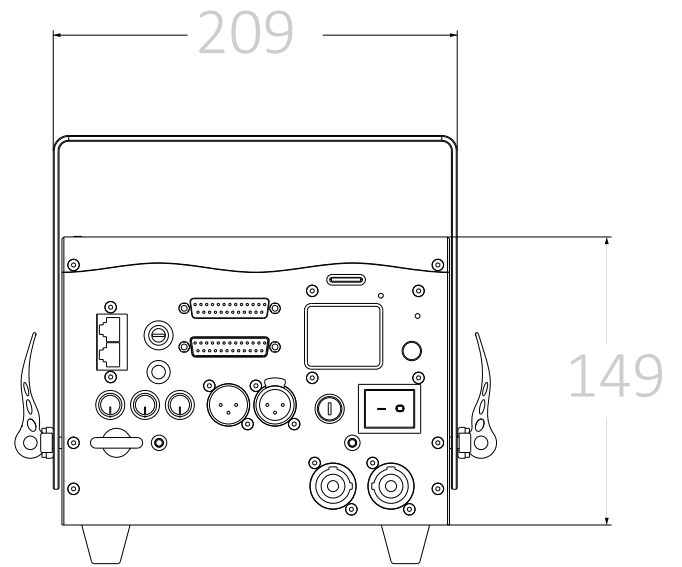
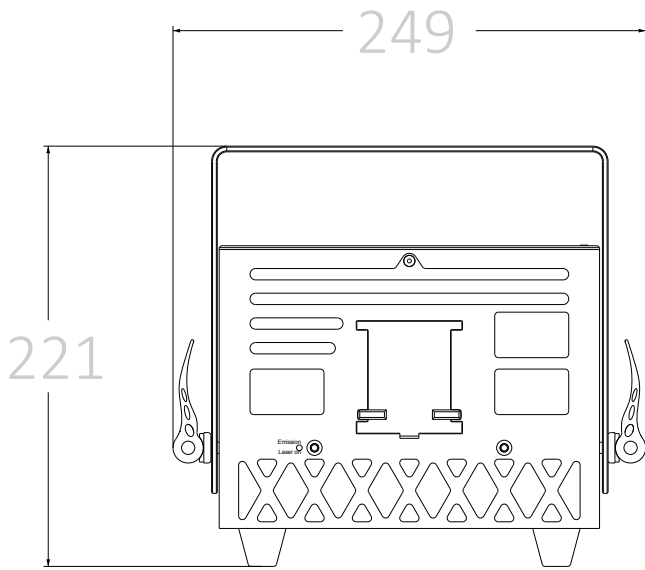
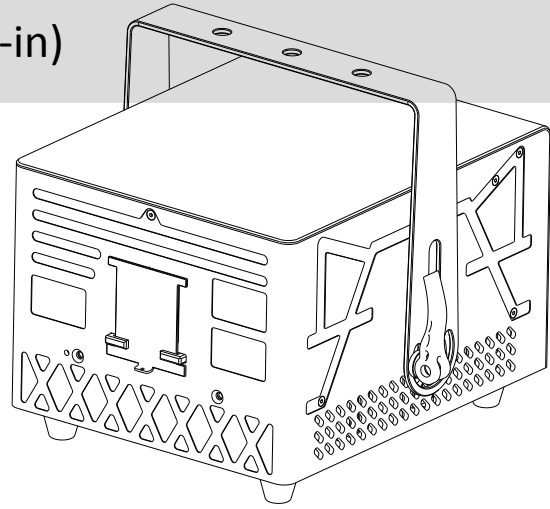

INTRODUCTIONS of PR8 SERIES

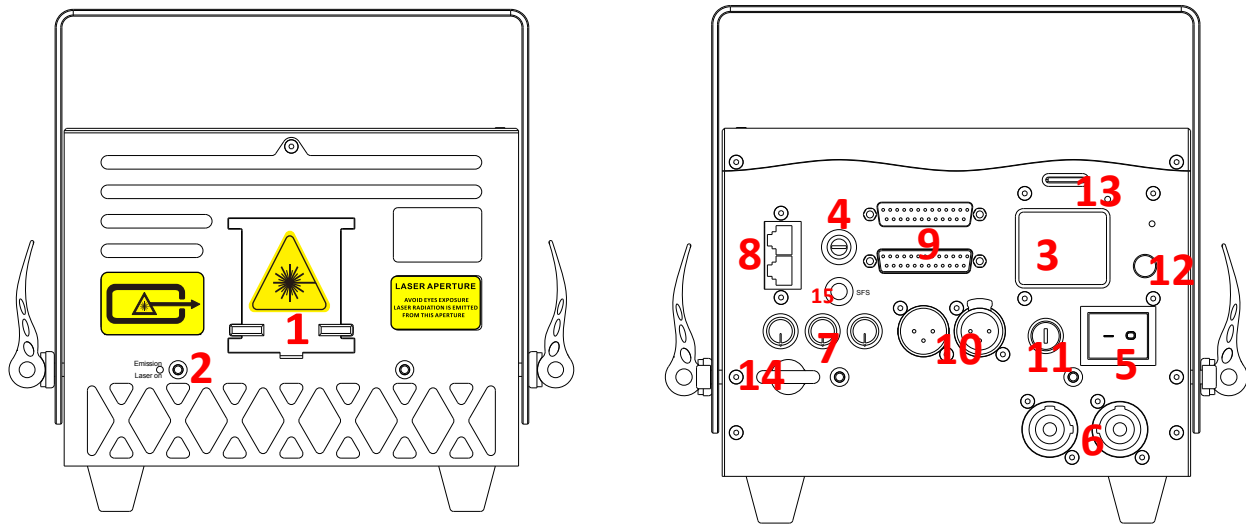

1	Laser aperture	(covered by masking plate) DO NOT look directly into this aperture once the masking plate gets loosen
2	Laser Emission	When this indicator is lit up the laser system is ready to emit the laser radiation as soon as it receives instructions from control software.
3	LCD Display	Integrated with multi settings on the projector, please refer to detailed settings (on Page 11.) for the LCD
4	Keyhole	Key Switch, laser output is available when the key is moved to position “on”
5	Power Switch	Power On/Off
6	PowerCON Input & Output	Power connections input and output
7	Color intensity knobs	R/G/B power intensity adjustments, rotate or anti-rotate to adjust output power
8	INTERLOCK (RJ45 jack)	Laser output is available only when the interlock is connected. It could be used to connect a laser emergency switch(E-stop box).
9	ILDA Input & Output	DB25 connections input and output for ILDA mode display
10	DMX Input & Output	3-pin DMX connections input and thru for DMX512 mode display
11	FUSE	Safety element; current rating 8amps
12	Menu knob for LCD Setting	The knob for the main settings on LCD, click it to wake the LCD and rotate it for corresponding status setting
13	SD-Card Slot	Slot for SD-Card which you may have your own laser files to export on
14	Safety Ring	The ring for enwinding a safety rope when the laser device will be installed on out-of-reach locations.
15	SFS	Scan-fail safety switch

★ Specifications of PR8 SERIES

Type of Laser	Pure diode-based full colors(semiconductor diode laser systems)												
Laser Classification	Class 4												
Laser Power(mW)	<table border="1"> <thead> <tr> <th>Model</th> <th>λ</th> <th>638nm</th> <th>520nm</th> </tr> </thead> <tbody> <tr> <td>PR10000-RGB</td> <td>R/3000mW+G/3000mW+B/4000mW</td> <td></td> <td></td> </tr> <tr> <td>PR9000-RGB</td> <td>R/3000mW+G/3000mW+B/3000mW(465nm)</td> <td></td> <td></td> </tr> </tbody> </table>	Model	λ	638nm	520nm	PR10000-RGB	R/3000mW+G/3000mW+B/4000mW			PR9000-RGB	R/3000mW+G/3000mW+B/3000mW(465nm)		
Model	λ	638nm	520nm										
PR10000-RGB	R/3000mW+G/3000mW+B/4000mW												
PR9000-RGB	R/3000mW+G/3000mW+B/3000mW(465nm)												
Scanning-system	40kpps ILDA@8° , Scan angle Max 60°												
Beam Size@aperture	4.5*6.5 mm												
Beam Divergence	<1.1 mRad												
Modulation	>60 KHz												
Power Supply	AC 100-240V, 50/60Hz												
Power Consumption	290W 280W												
Net Weight	6.95kg												
Dimension	245*201*150(H)mm, 280*249*221mm when bracket included.												
Controls	Auto, Sound to light, SD-Card, DMX512 , ILDA												
Operation Temperature	minus 20℃ to 40℃												
Protection Rating	IP54												
Safety elements	Keyed interlock, emission delay, magnetic interlock, scan-fail safety, mechanical shutter, adjustable aperture masking plate.												
Important statement	Due to Advanced Optical Correction technology used in our laser systems the optical power output of each laser colour within the system may slightly differ from the specification of respective laser module(s) installed. This does not affect the total guaranteed power output.												

Display mode introduction

- *Audio Mode(Sound mode): Preset programs triggered by sound, any proper sound will enable laser to output.
- *Auto Mode: The preset programs automatically display in Auto mode.
- *Prg Mode(SD playback in order): The preset/exported programs playback in sequence. Redact of the playlist please refer to **SD Card Introduction**.
- *ILD Mode(SD loop playback): Loop playback the single ILD file (extension named .ILD).
About .ILD format, please refer to **SD Card Introduction**.

Notice: the ILD here refers to playing the ILD file in the SD card, not the ILDA signal though software on computer.

DMX Mode: International standard DMX512 signal. In any of the above playback modes, the device can automatically recognize and switch to DMX mode after accessing DMX signal. The device has 17 DMX channels. Refer to DMX Table for details.

DMX consoles vary in different manufacturers' models. Please refer to the specific DMX console instructions.

ILDA (PC) mode: International standard ILDA signal is under computer control. In any of the above operating modes, when an ILDA signal with an interlock function is connected, the ILDA(computer) signal control has priority and the device will be displaying laser cues, programs in accordance to the ILDA signal output from laser controller on the PC.

In ILDA mode, a control hardware will be required, the recommended one should be FB3 controller from Pangolin, yet we can also provide this part with fair cost when purchase laser systems from here.

The ILDA software(laser controller) has different operating methods from different manufacturers. Please refer to the specific ILDA software instructions, to our experience the most commonly and widely being used is QuickShow from Pangolin.com.

SD Card Introduction

- *The system accepts only FAT32 file, formatting the new SD card to FAT32 type is required before use it.
- *Short file / File folder names , the file names is limited to 8 digits and the expanded name is limited with 3 digits, the names could only contain English letters, Arabic numbers, and underline, the others could not be recognized.
- *Equipped an exclusive SD card for the device and don't save the other files inside; the quantity for the file folders is limited with 20, and each file folder is limited to contain 256 ILD files and 10 PRG files at maximum.
- *PRG playlist: user could edit the playlist by text editor, the expanded name of the playlist is .PRG format.
The playlist is constituted by file name, play speed, and play times, "i" is the identification code stand for iShow, and comma "," is used to separate it.

Edit only one program each line; for example, if a program prg1.prg contains 3 files:

file1.ild,

file2.ild,

and file3.ild; play speed for file1.ild is 12K and repeated 3 times; play speed for file2.ild is

20k and play once, the file 2 was produced by iShow; play speed for file3.ild is 18K and

repeated 4 times; and the contents of the prg1.prg is as below:

File1.ild,12,3

File2.ild,20,1,i

File3.ild,18,4

- *After creating a file folder, do create a PRG file under this file folder by the same file name, and edit all the playing files into this PRG file, the speed edited here is the play speed in ILDA mode. For Example, create the file folder "Lasershow", and create the file "Lasershow.prg" under this folder; after adding a new ILDA file, we need to add this ILDA file to this PRG playlist, so that we could find this file correctly in the ILDA mode and play it by required speed

DMX Chart

CH	Function	Value	Description
1	Dimming	0-255	From the brightest to none.
2	Channels selection	0	NONE
		1-49	18 Channels mode (Default)
		50-99	33 Channels mode (bypassed)
		100-149	47 Channels mode (bypassed)
		150-255	6 Channels mode (bypassed)
3	Graphics selection	0-255	Every value for one pattern
4	Graphics selection: Option 2	0-239	Beam patterns
		240-255	Animations
5	Pattern boundary setting	0-49	Blanking, The larger the value, the smaller the pattern
		50-99	Blanking, The larger the value, the smaller the pattern
		100-149	Blanking, The larger the value, the smaller the pattern
		150-199	Blanking, The larger the value, the smaller the pattern
		200-255	Blanking, The larger the value, the smaller the pattern
6	Zoom	0-127	Size decrease
		128-159	Zoom + , From slow to fast.
		160-190	Zoom - , From slow to fast.
		191-255	Loop zooming±, From slow to fast
7	Central rotation	0-127	Manual angle adjustments, From slow to fast.
		128-192	Anti-clockwise , From slow to fast.
		193-255	Clockwise, From slow to fast.
8	LEFT-RIGHT movements	0-125	Manual adjustments
		126-164	From LEFT to RIGHT movements, From slow to fast.
		165-205	From RIGHT to LEFT movements, From slow to fast.
		206-244	Auto,irregular jump, From slow to fast.
		245-255	Sound control,irregular jump
9	UP-DOWN movements	0-125	Manual adjustments
		126-164	From DOWN to UP loop movements, From slow to fast
		165-205	From UP to DOWN loop movements, From slow to fast
		206-244	Auto,irregular jump, From slow to fast.
		245-255	Sound control, irregular jump
10	X-axis rotation	0-127	Manual adjustments
		128-159	Patterns twist, From slow to fast
		160-191	Reversed twist, From slow to fast
		192-255	Patterns surround Y-axis rotating, From slow to fast
11	Y-axis rotation	0-127	Manual adjustments
		128-159	Patterns twist, From slow to fast
		160-191	Reversed twist, From slow to fast
		192-255	Patterns surround X-axis rotating, From slow to fast
12	X-axis waves	0-9	NONE
		10-69	Small amplitude waves, From slow to fast.
		70-129	Medium amplitude waves, From slow to fast.
		130-189	Large amplitude waves, From slow to fast.
		190-255	Largest amplitude waves, From slow to fast.
13	Y-axis waves	0-9	NONE
		10-69	Small waves, From slow to fast.
		70-129	Medium waves, From slow to fast.
		130-189	Large waves, From slow to fast.
		190-255	Largest waves, From slow to fast.
14	Colors Intervals	0	Original colors
		1-255	Color intervals, From slow to fast.

15	Colors Changing selection	0-7	Original colors	
		8-15	White	
		16-23	Red	
		24-31	Yellow	
		32-39	Green	
		40-47	Cyan	
		48-55	Blue	
		56-63	Violet	
		64-95	Automatically changing among Red, Green and Blue	From slow to fast
		96-127	Automatically changing among cyan, yellow and violet	From slow to fast
16	Lightspot display	128-159	Automatically changing among White, Red, Yellow, Green, Cyan, Blue and Violet	From slow to fast
		160-191	segment beating among White, Red, Yellow, Green, Cyan, Blue and Violet	From slow to fast
		192-223	White, Red, Yellow, Green, Cyan, Blue and Violet colors stream	From slow to fast
		224-255	White, Red, Green and Blue colors stream	From slow to fast
17	Drawing	0-63	Lightspot	From dark to bright
		64-127	Lightspot blanking	From dark to bright
		128-255	NONE	
18	Patterns movements	0-74	Manual adjustments	
		75-104	Always drawing	From slow to fast
		105-144	Blanking	From slow to fast
		145-184	Drawing before and blanking after	From slow to fast
		185-255	NONE	
0-255	Limitation of patterns' movements	The larger the value, the smaller the movement		

INTRODUCTIONS OF RE-ALIGNMENTS. REF PR8 10W RGB.

Laser combinations would be misaligned because of many external factors e.g. lasers got fallen from height, or shocking during transportation, long time of being used, etc.

All of these factors would cause the well aligned lasers out of shape, misaligned.

If there would be any necessary to re-do RGB alignments, there are many procedures to be completed in a high powered RGB laser module. Because each single laser color has more than 1 only diode get combined, thus a RGB high power module would have many permutations and combinations on alignment procedures.

Generally, if the single color are stay still(overlay itself),end users would need to do the basic alignments on RGB balance only. Please read the steps as described herein for reference of how to make alignments on this module:

The very first step is to judge by eyes visual if the RGB(white balance) out of shape. Easy to know whether lasers are misaligned or not from projecting a white circle, you will then see if the white balance is with slight or severe splitting.

Pictures below were taken from the 15W system and its RGB laser module.

Step 1. Cut off all power supply

Step 2. Open up the cover of the laser show system then access to overall internal of the system.

Laser module is set under the power supply unit, you should unscrew this power supply unit with its baseplate and put them on the other side in the system.

Here's the 10W RGB module alone, we're giving some simplified procedures for re-alignments of the red laser.

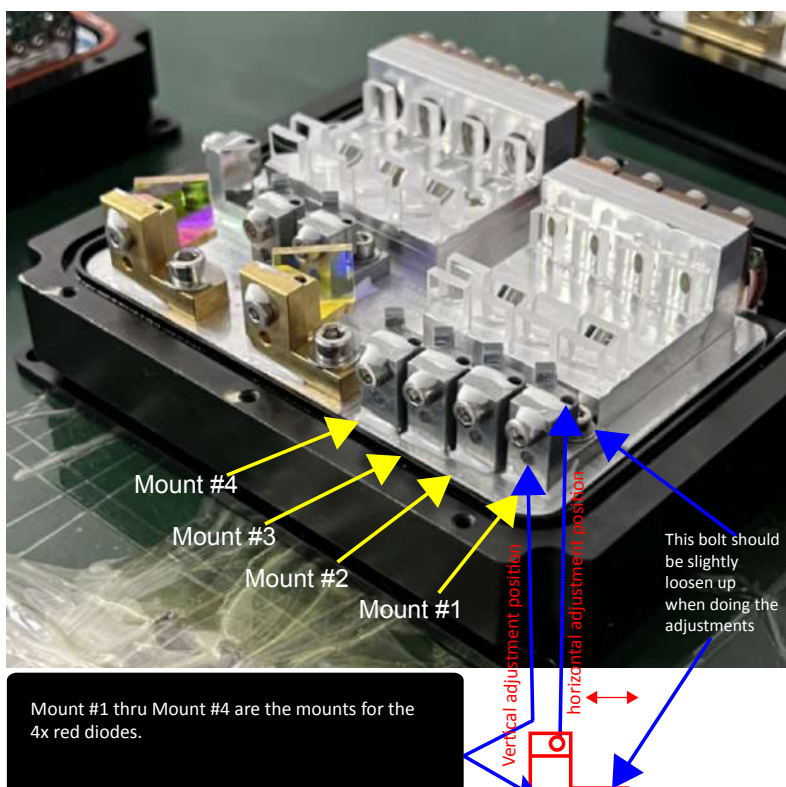

Steps

1. Bring the laser devices into a room with good conditions of : temp around 20~27 C and humidity must be less than 50%. Better turn up an air conditioner to create these conditions.
2. Without power supply, open up the laser projector and the cover of the laser module accordingly.
(Keep the laser module maintain, do not remove it from the baseplate of the projector)
3. When the step 2. is well done, power up the laser projector and then enable the laser output a circle beam(operating thru laser software).
4. Now, you can start doing re-alignments by viewing the laser circle's beam shape.

If the red beam is completely out of the shape, you need to adjust the optic mounts #1 to #4, one by one(or maybe not need to adjust all of them, this will depend on the processing of the work, once the red beam overlap on the green and blue well by only adjusting one or two of the mounts, then you should stop the adjustments, and tightly screw up the bolt which is used for locking the complete mount.

For intuitive judgment, please look at the marks on the actual 10W module as the picture on the left side in this page.

For reference, you should use an appropriate allen key to insert into the positions on the mount to do the adjustments.

Maintenance Instruction

The device is mostly installed in the location that there is dust, haze, and smoke, which are easily pollute the lens and decrease the output brightness; these particles also easily pollute the light case, fans, PCBA, block the heat dissipation, and reduce the stability of the electronic components; so the regular cleaning is very necessary and important to keep the maximum light output and increase the stability and lifetime. It is recommended to clean the window lens, outside case, and fans every 2 weeks, and clean the internal of the stage light every 4 weeks; the cleaning frequency should be higher in the severe working condition.

Note:

Only an qualified & authorized technician(s) is(are) allowed to clean the internal parts, improper operations for the internal cleaning could cause serious damage to the device. It is forbidden to use the corrosive chemicals to clean the device, the pure alcohol and acetone is recommended to clean the lens.

Clean the lens carefully and gently, don't touch the lens by any hard and sharp materials.

After sales service and warranty

* One year's warranty for the device.

* The components and accessories costs are charged after the warranty period.

*Warranty voids for the damages or injuries caused by force majeure, like, earthquake, typhoon, and so on.

*Warranty voids for the damages or injuries caused by improper operation and projection, such as wrong input voltage, water immerse, physical shock, and so on